

SOLUTION "A"
AUSFÜHRUNG "A"

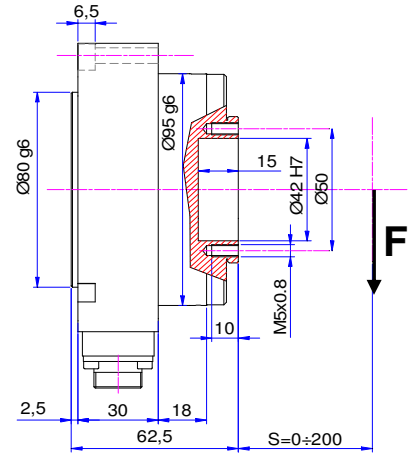

SOLUTION "B"

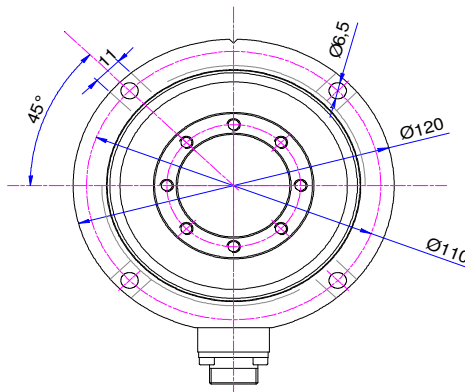
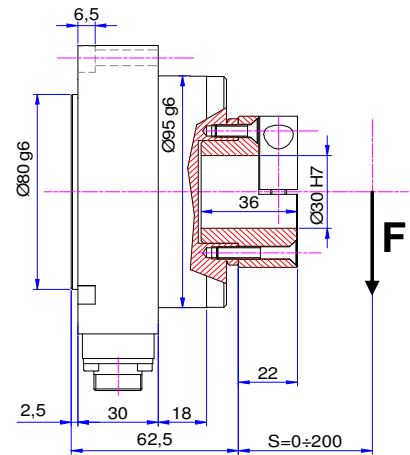
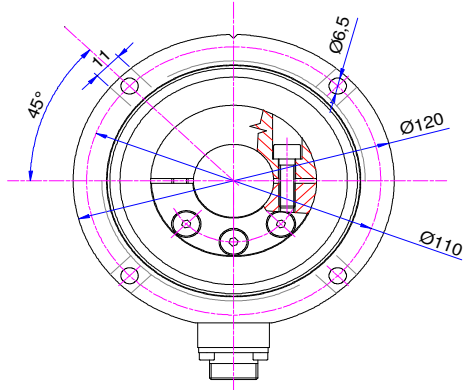
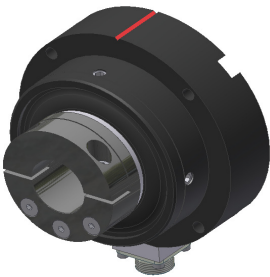

Dimensions in mm
Abmessungen in mm

Nominal Force F (N) Meßbereich F (N)				Material Material
125	250	500	1000	Avional
1500	2000	2500	3000	Steel / Stahl

Technical Data		Technische Daten
- Ultimate Load	300%F S=0÷50mm 250%F S=51÷100mm 200%F S=101÷200mm	- Bruchlast
- Sensitivity	1 mV / V	- Empfindlichkeit
- Accuracy	< 0.2 % F	- Genauigkeit
- Repeatability	< 0.2 % F	- Wiederholgenauigkeit
- Combined error	< 0.3 % F	- Totalfehler
- Zero bridge balance	±1% F	- Nullpunktabweichung
- Temperature effect on zero	± 0.1% F / 10 °C	- Temperatureinfluß auf den Nullpunkt
- Nominal temperature	+10 ... +60 °C +10 ... +100 °C	- Nominaltemperaturbereich
- Working temperature	-10 ... +80 °C -10 ... +130 °C	- Arbeitstemperaturbereich
- Bridge resistance	350 Ohm	- Brückenwiderstand
- Maximum supply voltage	12 Vdc	- Max. Speisespannung
- Protection Level	IP54	- Schutzgrad
- Male connector, 4 poles, Ø18	MIL	- Zwitterstecker, 4 polige, Ø18
- Male connector, 5 poles, Ø21	ITT Cannon	- Zwitterstecker, 5 polige, Ø21
- Force application axis F	0 ÷ 200 mm	- Achse zur Lastauftragung F

**ASSEMBLING EXAMPLE
EINBAUBEISPIELE**

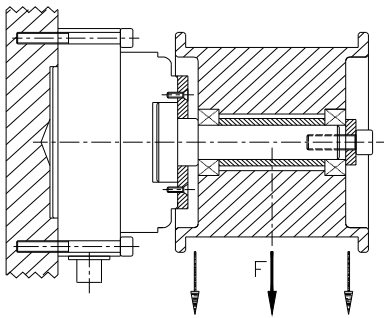

**SOLUTION "A"
AUSFÜHRUNG "A"**

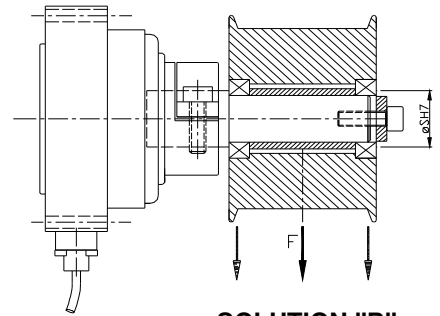
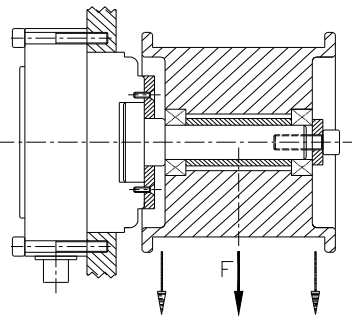

SOLUTION "B"

	Male connector <i>Zwitterstecker</i>	Suggested Female connector <i>Empfohlen Steckerhülse</i> (90°)	
MIL	IPT02A-8-4P-N436	IPT06A-8-4S(SR)-N436	IPT08-EM8-4S
ITT Cannon	SRCN2A 165P	SRCN6A 135S	-----

**ELECTRICAL CONNECTION
ELEKTRISCHE ANSCHLÜSSE**

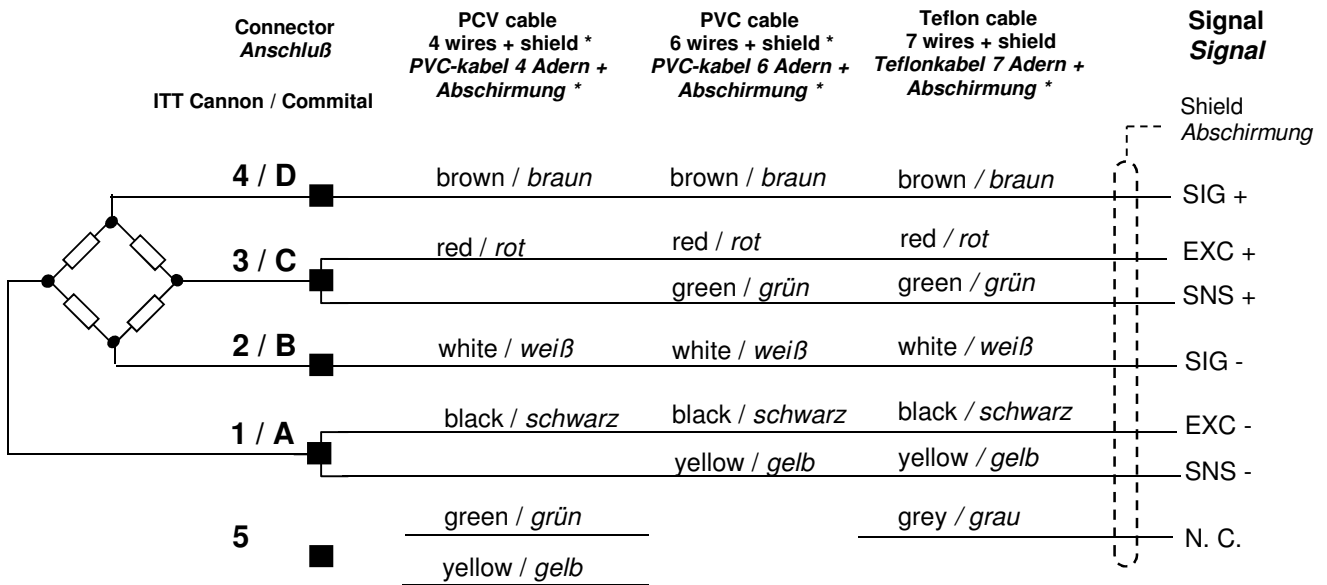

*Color code used when the cable is also supplied by ASA-RT

**ORDER CODE
BESTELLCODE**

