

No.	ACCOUNT	DATE	NAME
①			
②			
③			

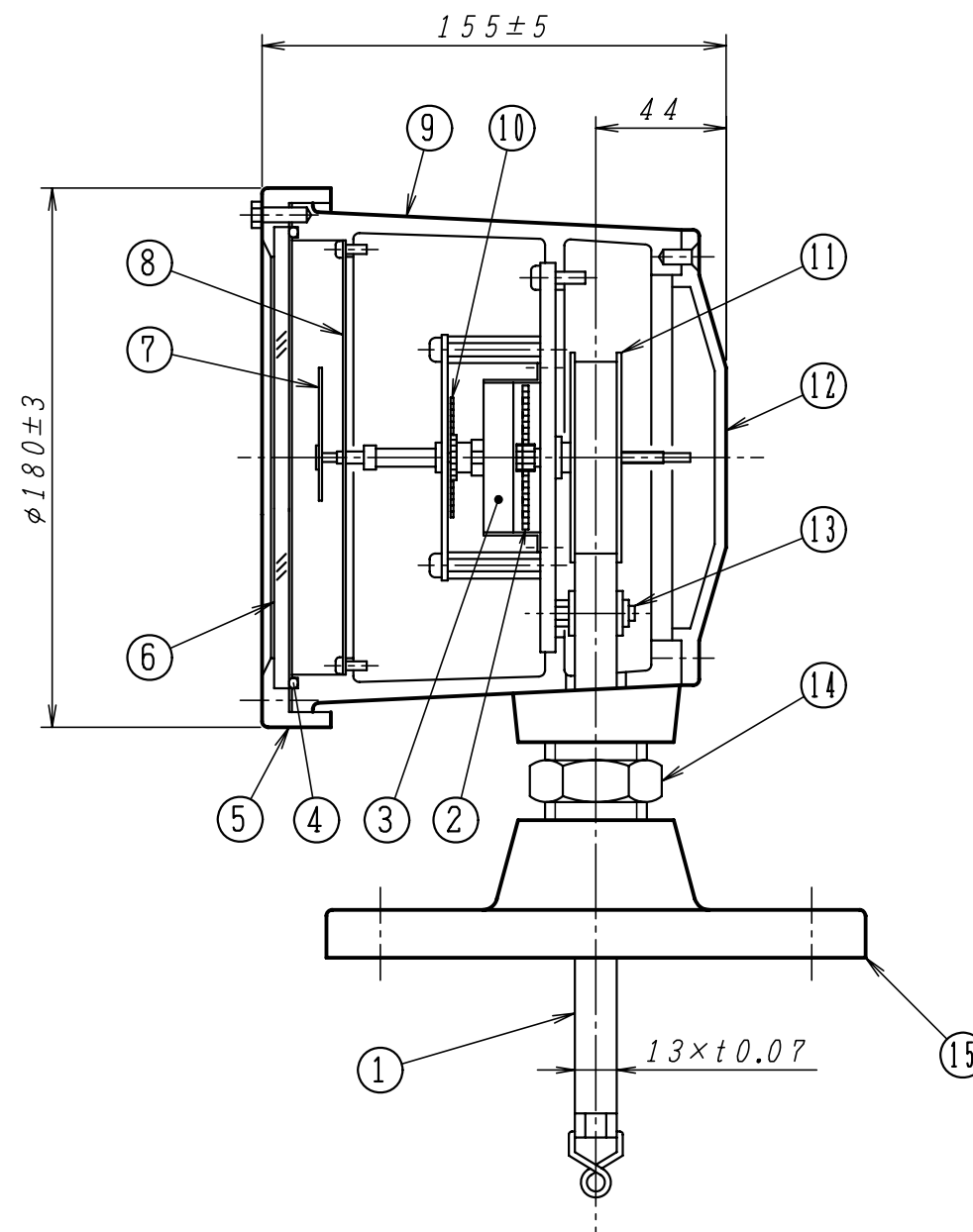
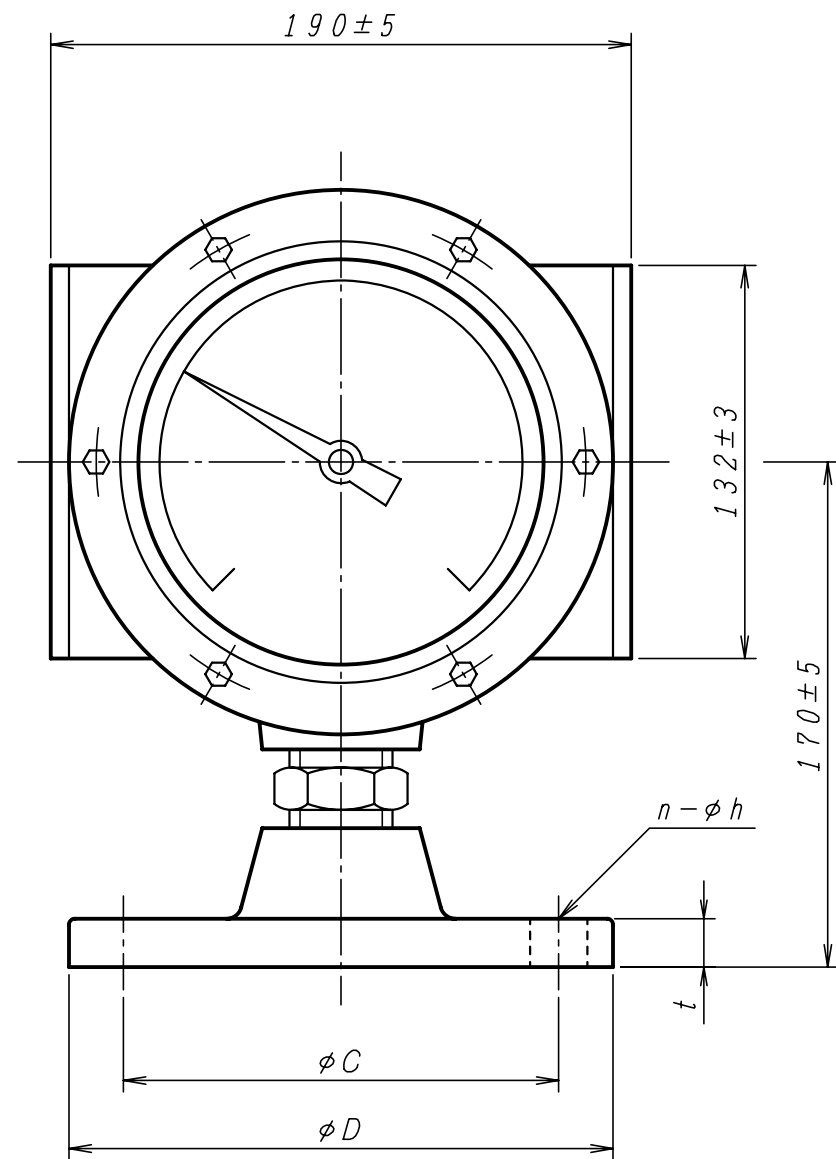

DATA TABLE OF FLANGE					
NOMINAL SIZE	D	t	C	n	h
JIS 5K-80A	180	16	145	4	19
JIS 5K-100A	200	16	165	8	19
JIS 10K-80A	185	18	150	8	19
JIS 10K-100A	210	18	175	8	19
JIS 10K-50A	155	16	120	4	19

10	GEAR	2	C3713/C3604	
9	INDICATOR BODY	1	AC2A-F	
8	SCALE PLATE	1	A5052	
7	POINTER	1	C5191	
6	GLASS	1	BOROSILICATE GLASS	TEMPERED GLASS
5	FRONT COVER	1	AC2A-F	
4	O RING	1	NBR	AS568-256
3	SPRING ASSEMBLY	1set	SUS304	SPRINGMOTOR
2	GEAR	2	S45C	QUENCHING
1	TAPE	1	SUS304	
No.	NAME OF PARTS	PIECE	MATERIAL	REMARK

CHECKED _____ TRACED _____ DESIGNED _____ PROJECT. _____ SCALE NONE DATE '11. 5.13

15	FLANGE	1	AC2A-F	
14	NIPPLE	1	FCMB	1"
13	PULLEY	1	PTFE	
12	BACK COVER	1	AC2A-F	
11	PULLEY	1	AC2A-F	
No.	NAME OF PARTS	PIECE	MATERIAL	REMARK

 3rd. ANGLE	TITLE	LG-100 LG-101 DIAL TYPE LIQUID LEVEL GAUGE
	DRW. No.	REFERENCE DRAWING RD-01- [] [] [] [] [] [] [] [] [] []
WAKO KEISOKU Co., LTD.		