

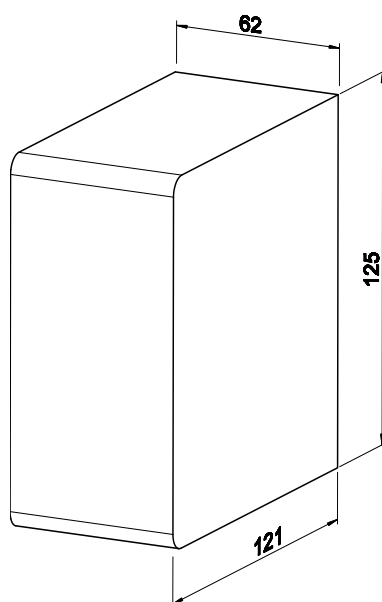

- 480 watts output power
- Only 62mm wide
- Output DC: 22 - 29 V
44 - 54 V
54 - 80 V
- Powerboost up to 150%
- Input AC: 120 / 230 V
- Input with internal fuse
- Overtemperature protection
- Primary and secondary overvoltage protection
- Operation in any assembly position
- 3 Year Warranty





Dimensions W x H x D (without connectors): 62 x 125 x 121 mm
Detailed dimension drawing please on request or www.mgv.de

There should be a distance of at least 20 mm between the air inlets and outlets and the surrounding devices. Please ensure that the air extracted is not immediately sucked in again.

ORDER DATAS						
Ua V	Ia A	Preset range Vo V	Type number Order number DIN rail	Type number Order number Wall mounting	Type number Order number Universal fixing device	
24	0 - 20	22 - 29	SPH500-2420 14.5946.800	SPH500-2420 14.5946.805	SPH500-2420 14.5946.806	
48	0 - 10	44 - 54	SPH500-4810 14.5946.900	SPH500-4810 14.5946.905	SPH500-4810 14.5946.906	
72	0 - 6.7	54 - 80	SPH500-7207 14.5944.400	SPH500-7207 14.5944.405	SPH500-7207 14.5944.406	

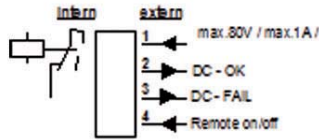
**AC / DC POWER SUPPLY
PRIMARY SWITCHED · SINGLE OUTPUT
SPH500 SERIES**

1. INPUT		6. EMC	
Input voltage range V_i	AC 90 - 132 V and 180 - 264V, 50/60 Hz automatical switchover	Mains feedback / PFC	EN 61000-3-2 Class A only with ext. PFC 12mH/4, 5A/230VAC
Efficiency	24V/48V: typ. 86%, 72V: typ. 88%	Flicker	EN 61000-3-3
Input current limitation	$\leq 70 A_{peak}$ typ. in cold state $\leq 150 A_{peak}$ typ. in hot state	Interference immunity	EN 61000-6-2 Industrial generic standard EN 61000-4-2 8/15KV EN 61000-4-3 noise level 10V/m (Krit. A) EN 61000-4-4 4KV (Krit. A) EN 61000-4-5 4/2KV (Krit. A) EN 61000-4-6 noise level(Krit. A) EN 61000-4-11
Internal fuse	16ATH / 250Vac	Interference emission	EN 61000-6-4 Industrial generic standard EN 55011 Class B Radiation depends on assembly
2. OUTPUT		7. OPERATING DATA	
Preset range V_o	DC 22 - 29 V, 44 - 54 V, 54 - 80 V V_o will be saved after 1s	Temperature range	-25°C...70°C, integral, temperature-regulated fan, sucking in air from below
Adjusted by MGV	DC 24 V, 48 V, 72 V + 0.5%	Derating	3% / K at +60°C (see diagram)
Max. Outputpower	480W - Powerboost 720W ($V_o \geq V_{o_{nom}}$)	Weight	1kg
Powerboost (only in boostmode)	Boost 500ms up to 150% I_{nom} possible, after that min. 500ms break necessary	Due to the integrated fan, the SPH500 can be installed in any position. The passage of air must not be obstructed by installation. The distance to the air vents must be at least 20 mm. Fire protection must be ensured via the outer casing system.	
Operation indicator	green led for ok / red led for error	8. MECHANICS	
Ripple	120mV _{ss} typ.	Connection: mains	4-pol terminal
Noise voltage (20MHz)	200mV _{ss} typ.	input	1.5 - 4/6 mm ² strand / wire tightening torque 0.6 - 0.7 Nm
Temperature coefficient	$\leq 0.025\%$ / K	Load output	4-pol terminal 1.5 - 4/6 mm ² strand / wire tightening torque 0.6 - 0.7 Nm
Switch on / switch off	No V_o overshoot (soft-start)	Control signals	4-pol terminal, pluggable 0.1 - 0.5 mm ² strand / wire
Start-up delay	< 1s typ. (at 230Vac)		
Rise time	< 15 / 40 / 80ms typ.		
Back feeding voltage	24 V: up to 35 Vdc 48 V: up to 63 Vdc 72 V: up to 100 Vdc	Assembly	All systems can be snapped onto a symmetrical 35mm DIN-rail according to EN 50022 with a diameter of 1 to 2.5 mm or directly be screwed onto the wall. Please notice the assembly conditions.
Serial connection	yes (max. 2 identical power supplies)	9. EXPLANATION	
Parallel connection	yes (max. 3 identical power supplies)	PE-Schutzkontakt 	Protective conductor Do not use supply without PE-connection!
Battery operation	after consulting MGV possible	L1 / N	Mains phase / neutral conductor
3. REGULATION		+ / -	Loadoutput (V_o)
Line regulation	< 0.2% for V_o at $V_{i_{min}}$ - $V_{i_{max}}$	Relay OK/FAIL	Monitoring connections
Load regulation	< 0.5% for V_o at I_o 0 - 100% boost mode < 3.0% for V_o at I_o 0 - 100% parallel m.	Control signal OFF	external on/off
Response time	typ. 1ms at I_o 20 - 80%	DIP - switch	selection boost- and parallelmode
4. PROTECTION AND CONTROLLING		UP / DOWN - switch	adjust the output voltage
Overvoltage protection (OVP)	24 V: approx. 31 Vdc 48 V: approx. 58 Vdc 72 V: approx. 88 Vdc	 Please read the MGV safety instructions on our homepage before use: www.mgv.de	
Undervoltage monitoring	24 V: approx. 18 Vdc 48 V: approx. 35 Vdc 72 V: approx. 52 Vdc automatical repeating		
Current limitation	105 - 140% I_{nom} (see diagram) output permanent short-circuit proof		
Overtemperature protection	Switches off if inside temperature is too high, reconnection with hysteresis		
Relay contact	Relay contact (max. 80V / 1A / 30W), changing at V_o < 18V / 35V / 52V or OVP from OK to FAIL (red LED)		
Remote OFF	external switch-off with with 4-60Vdc/5mA		
5. SAFETY / STANDARDS			
IEC60950, UL60950, UL508 CSA22.2-60950, CSA22.2-107.1 IP20, safety class 1 pollution degree 2			
Ensure fire protection by means of the surrounding housing system			

**AC / DC POWER SUPPLY
PRIMARY SWITCHED · SINGLE OUTPUT
SPH500 SERIES**

10. NOTES

DIP-switch position

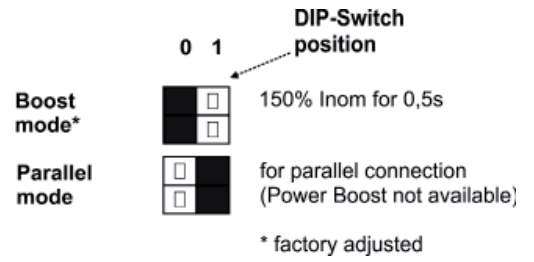

Current limiting characteristics (typ.)

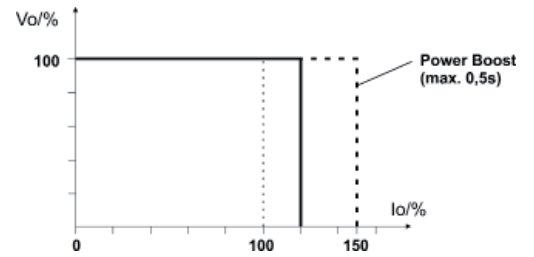

Derating

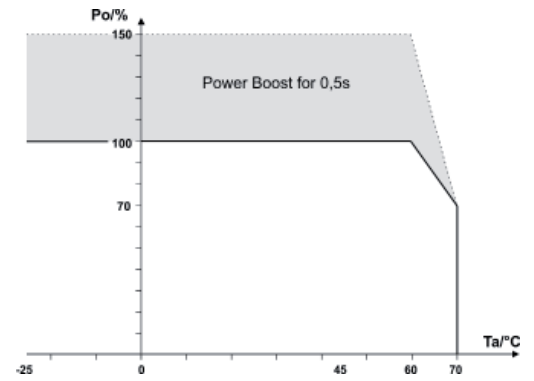

Remote ON/OFF

Connecting an external DC source:

Connect positive pole of the DC source to pin 4. Connect negative pole (GND) of the DC source to the negative output connector of the SPH500. Adjust 5V.

